

# COMMUNITY HELPERS

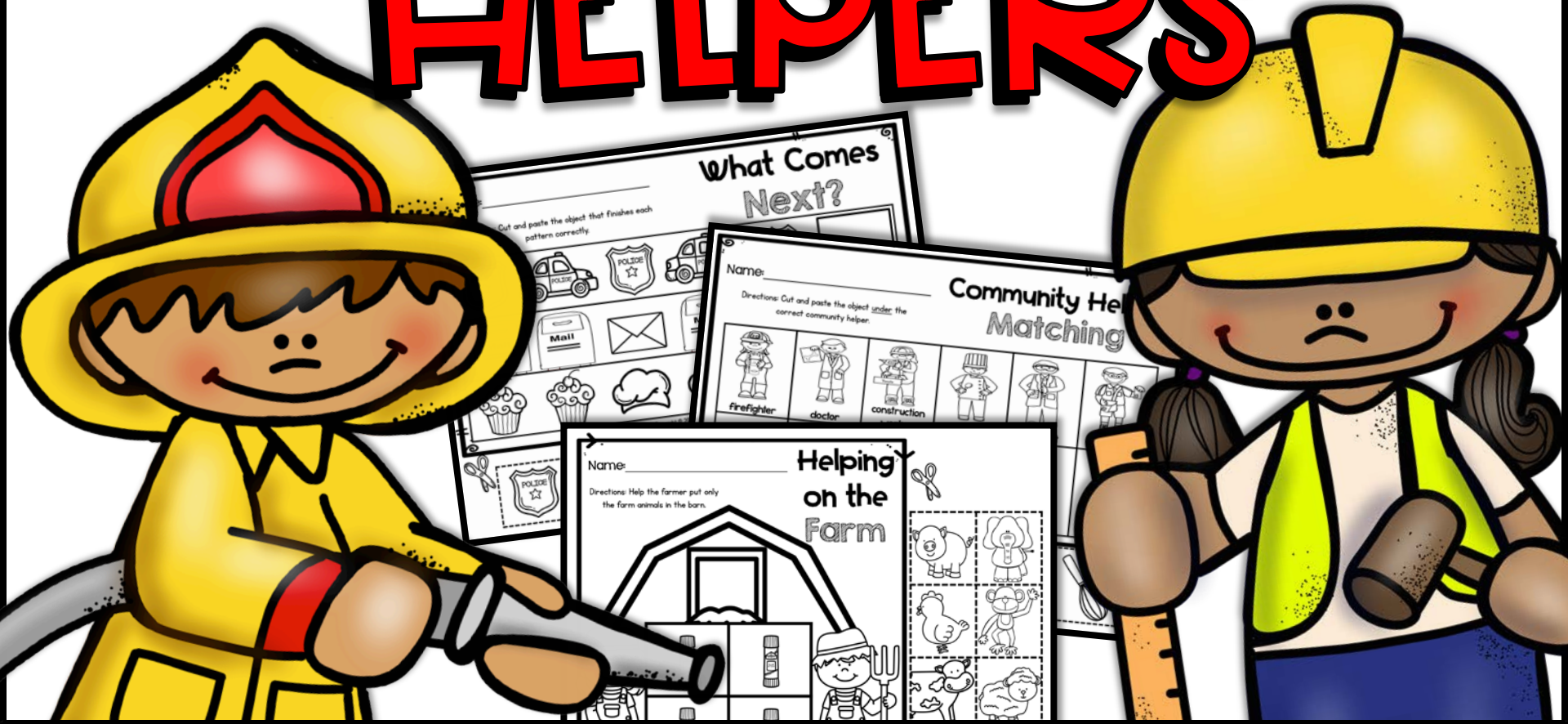

BY: CURRICULUM CASTLE



Curriculum Castle units are designed to give your students a well-rounded learning experience that stimulates their cognitive learning and creativity.

We believe that all great learning takes place through hands-on and interactive activities, and what you will find in each unit are supplemental lessons and ideas to make learning about a particular subject come to life in a concrete way.

Ideally, these units are a wonderful way to explore concepts that you have already introduced using books and discussion. That is why we begin each unit with a recommended reading list that is designed to help you gather the information needed for each topic.

Our products are perfect for classroom environments and homeschool learning. If you have any questions or comments about our units, please feel free to contact us at:  
[curriculumcastle@gmail.com](mailto:curriculumcastle@gmail.com).

Thank YOU FOR DOWNLOADING! 😊

# Recommended Book List

Find these books at your local library or buy online and start your own personal library.



Helpers in My Community by: Bobbie Kalman

Whose Hat Is This? by: Katz Cooper

Career Day by: Anne Rockwell

A Day in the Life... (Series) by Heather Adamson

Show Me Community Helpers by: Clint Edwards

When I Grow Up by: P. K. Hallinan

Whose Tools Are These? by: Amanda Tourville

Jobs People Do by: D.K. Publishing

# Community Helper Word Wall



**dentist**

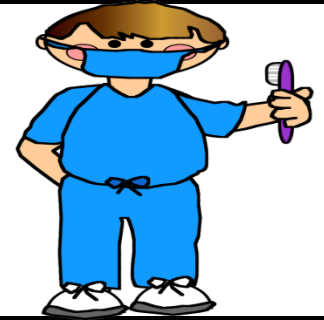

**doctor**



**farmer**



**firefighter**







police officer

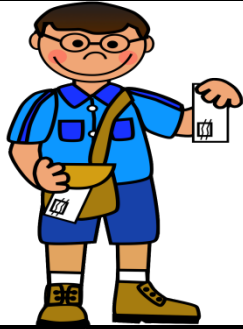

mail carrier



teacher



construction  
worker





baker



judge



scientist



trash  
collector



# Community Helpers

Color and cut out the mini book pages (7&8). Read this book as a class!

# Community Helpers

read and colored by:

---

copyright 2013 Curriculum Castle

1



Many people in our community help us everyday. Let's meet some of them now!

2

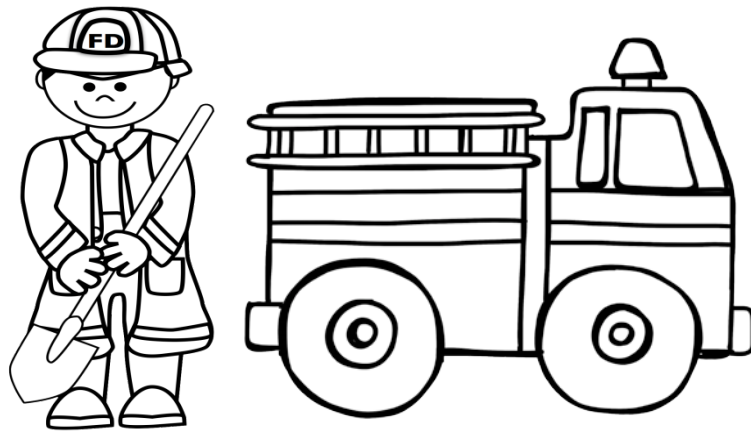

I am a firefighter. I help put out fires and drive a big red truck.

3

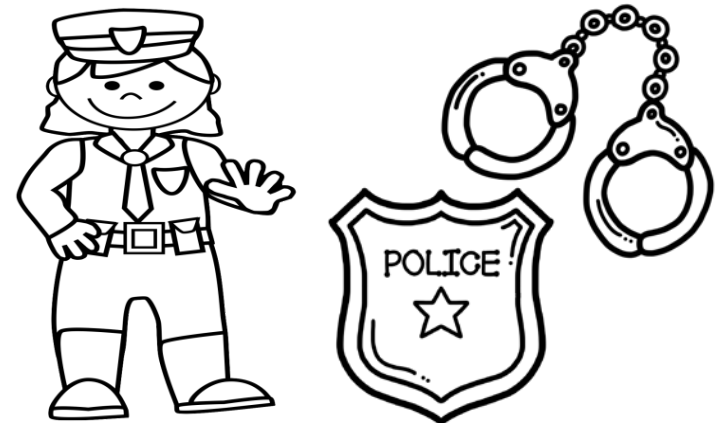

I am a police officer. I protect the people in the community and keep them safe!

4

# Community Helpers

Color and cut out the mini book pages (7&8). Read this book as a class!

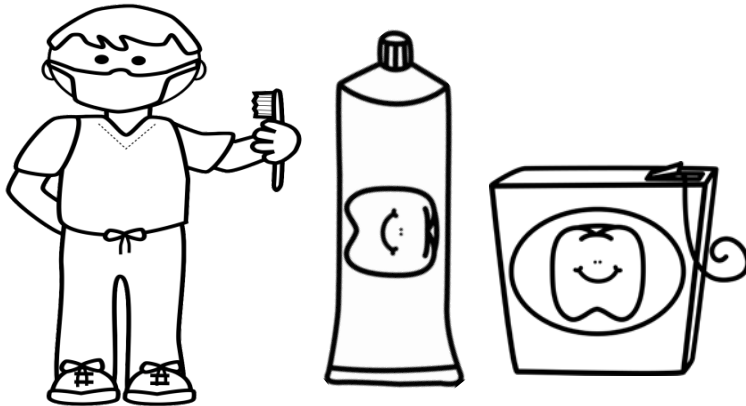

I am a dentist. I teach people how to keep their teeth clean and healthy.

5

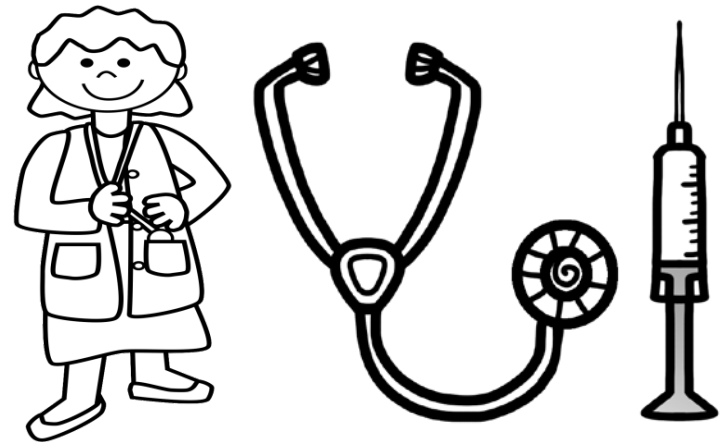

I am a doctor. I take care of people when they are sick.

6

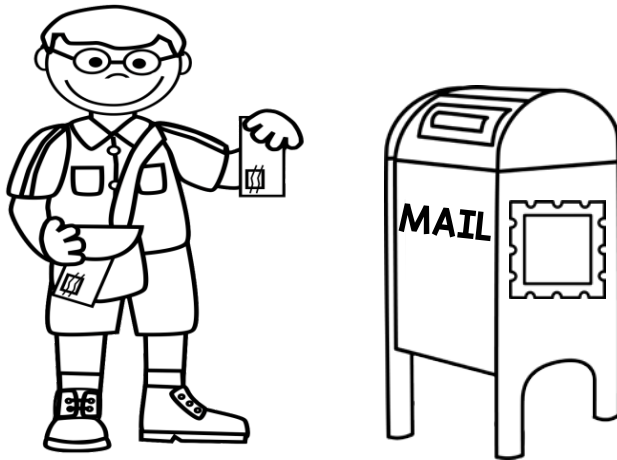

I am a mail carrier. I make sure to deliver letters and packages!

7

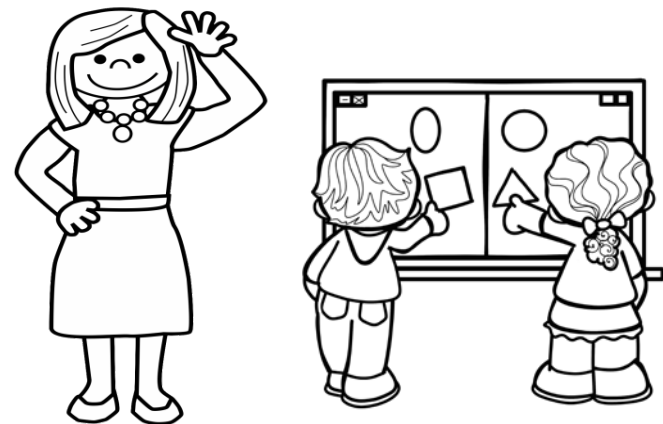

I am a teacher. I help students learn many things like reading and writing.

8



# Community Helper Tool Belt

## Materials:

- ✓ sentence strips
- ✓ tool belt template (pages 10-12)
- ✓ crayon or markers
- ✓ glue
- ✓ scissors
- ✓ stapler



## Directions:

1. Have students color and cut out the tool belt pictures of their choice on pages 11-12.
2. Give each student one "community helper" label for the front of their belt.
3. Glue the tools and label onto the sentence strip(s).
4. Fit the sentence strip onto the student's waist and secure with a stapler.
5. Discuss with the children how each tool represents a different community helper!

Tools included: magnifying glass (scientist/detective), hammer (construction worker), stethoscope (doctor/vet), toothbrush (dentist), ruler (teacher), cooking utensils (baker/chef), police badge (police officer), fire extinguisher (firefighter).



my  
community  
Helper  
TOOL BELT!

my  
community  
Helper  
TOOL BELT!

my  
community  
Helper  
TOOL BELT!

my  
community  
Helper  
TOOL BELT!

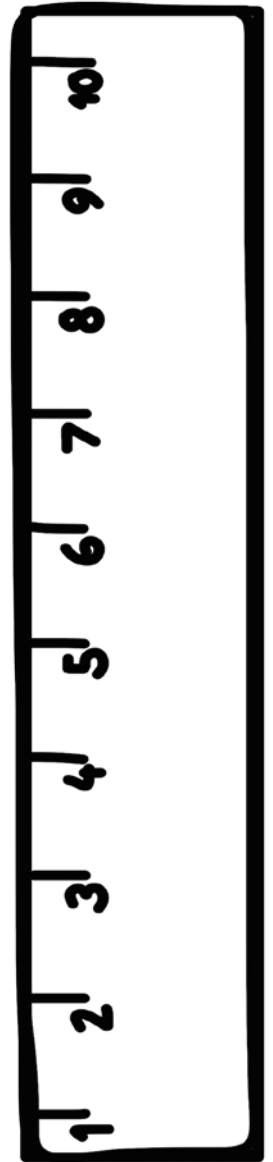
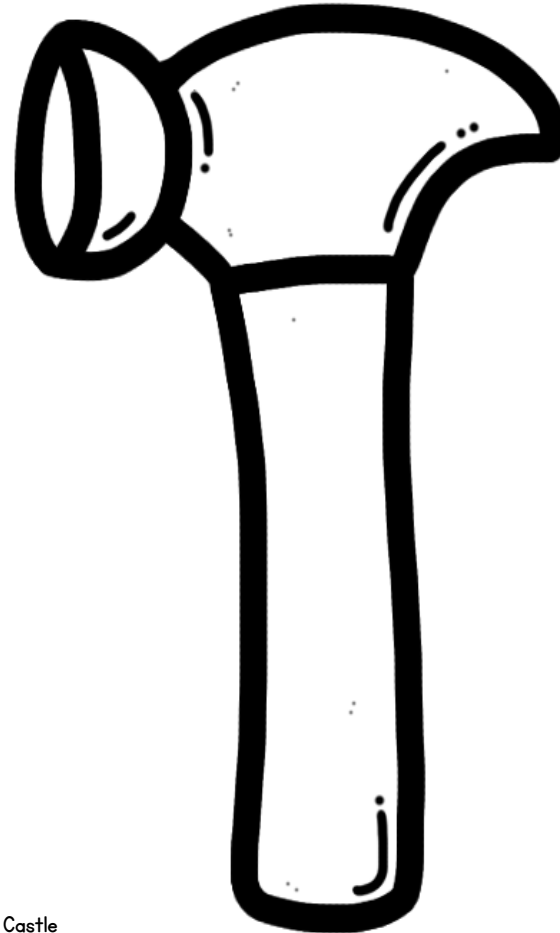

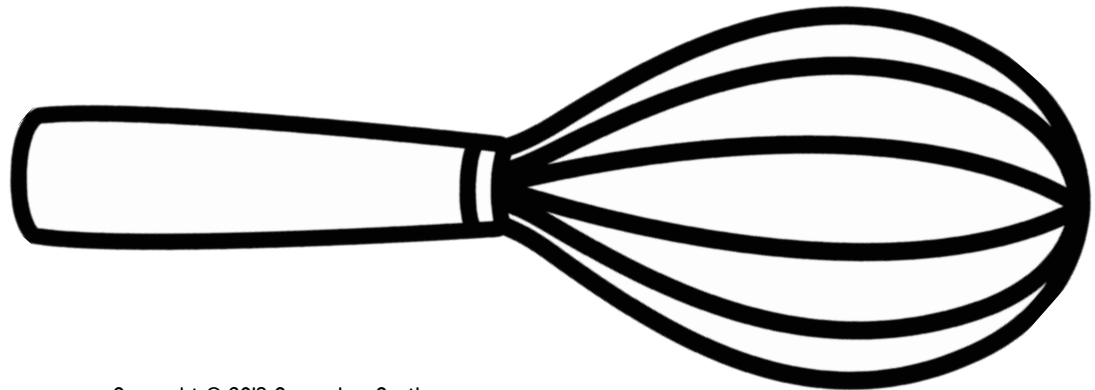
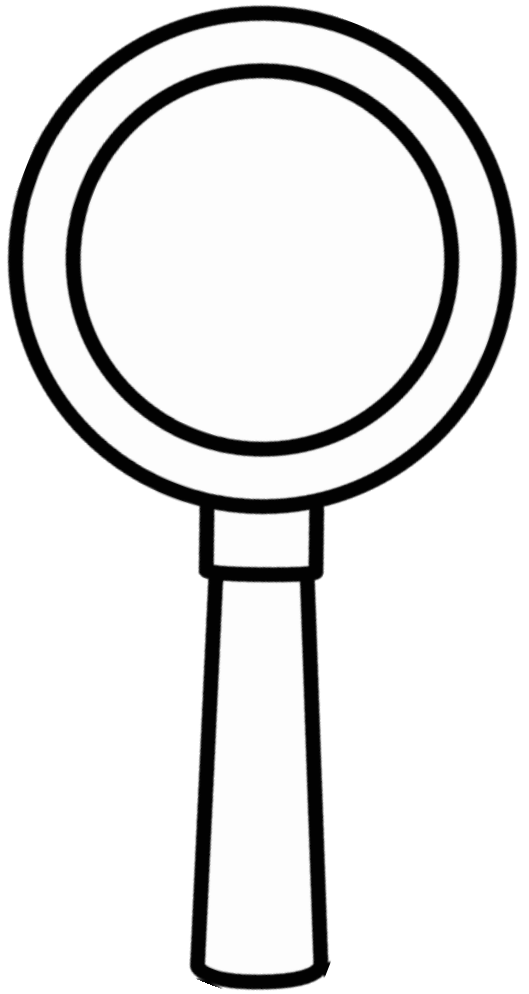
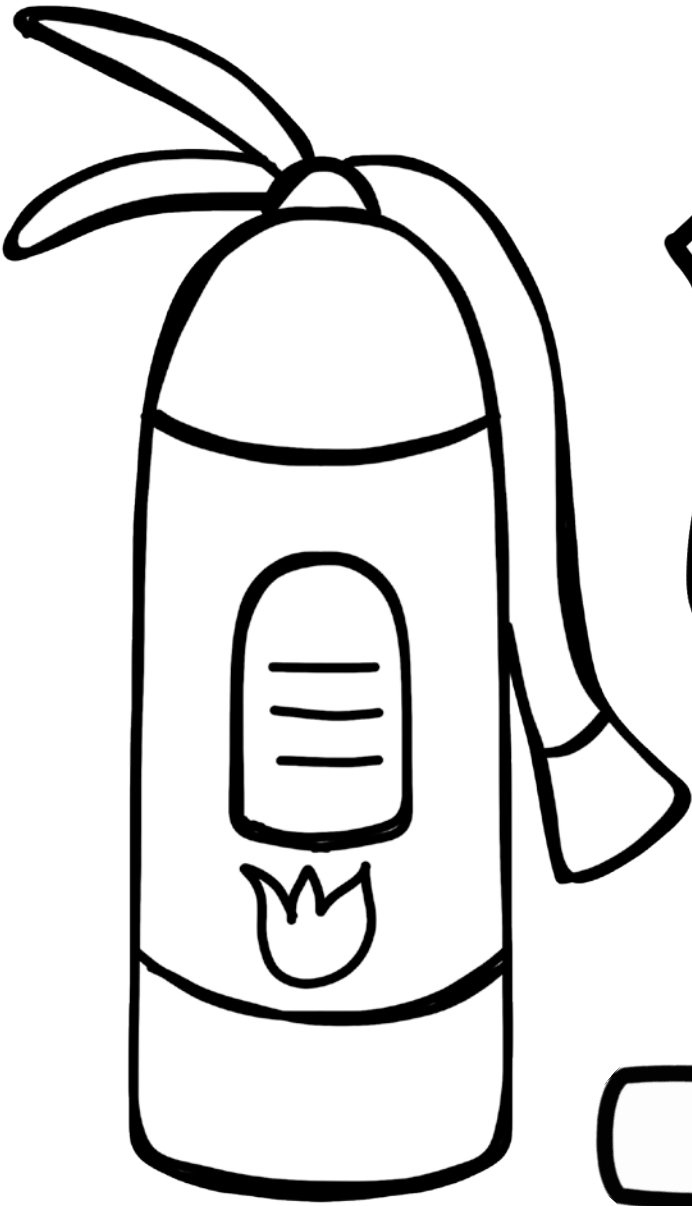

# Helpers on the Road

## Materials:

- ✓ black construction paper (large)
- ✓ helper vehicles template on pages 14-15
- ✓ crayon, markers, or watercolor
- ✓ white chalk or crayon
- ✓ scissors
- ✓ glue

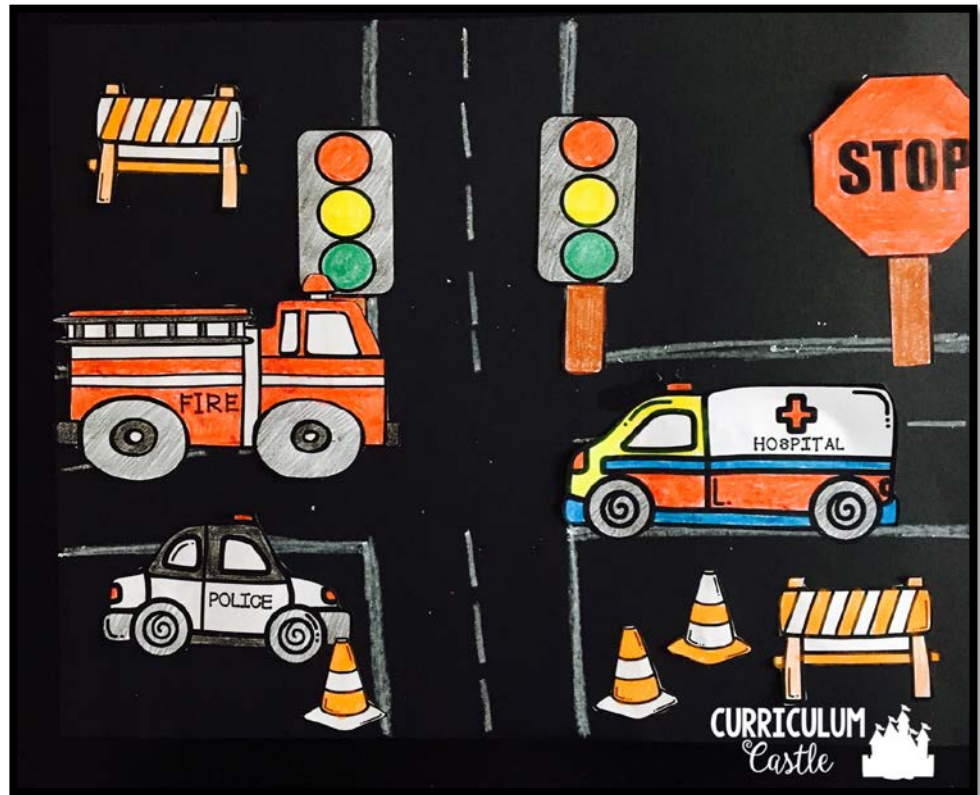

## Directions:

1. Have students color and cut out the vehicle and road accessories on pages 14 & 15.
2. On a large piece of black construction paper, guide students as they draw a road/intersection using white chalk or paint.
3. Students can spend some time playing interactively on the "road".
4. Glue down the vehicles and road accessories to create a city street scene!



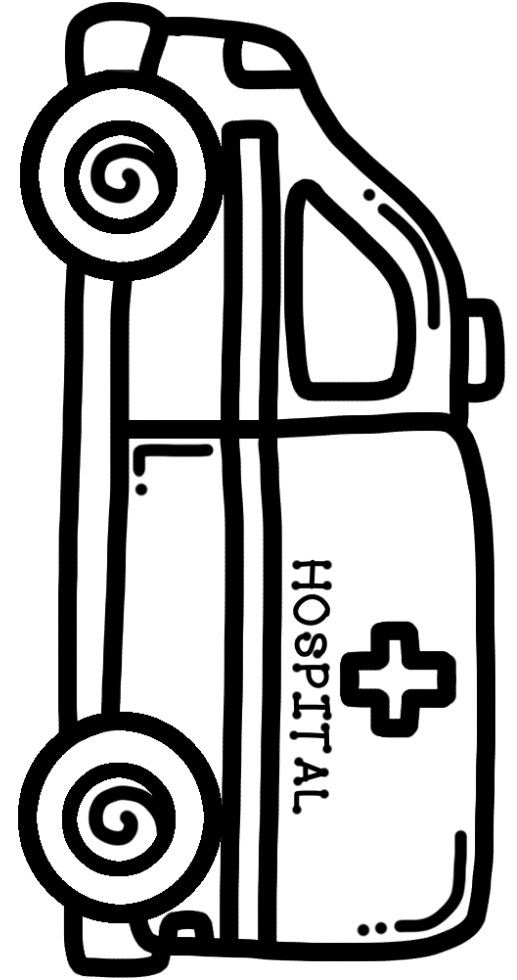
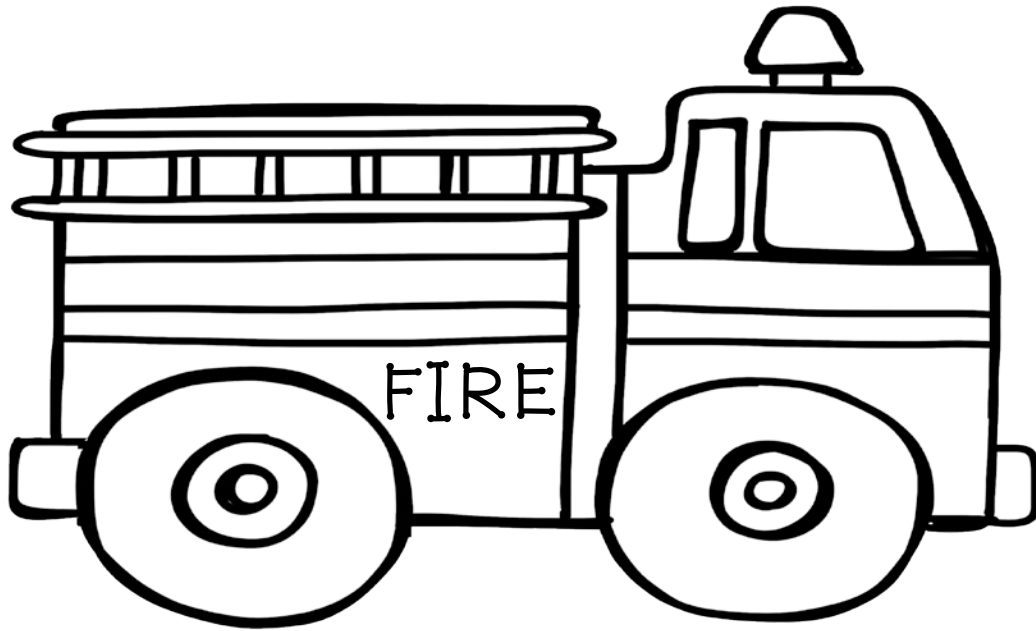

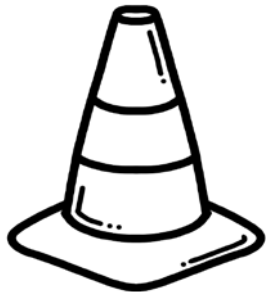
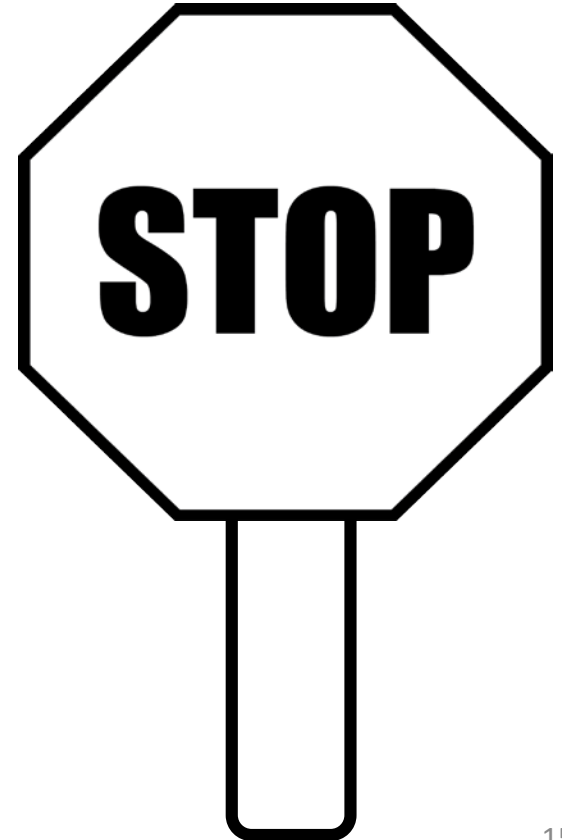
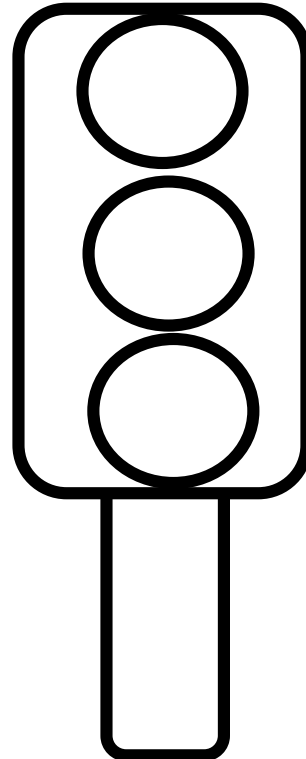
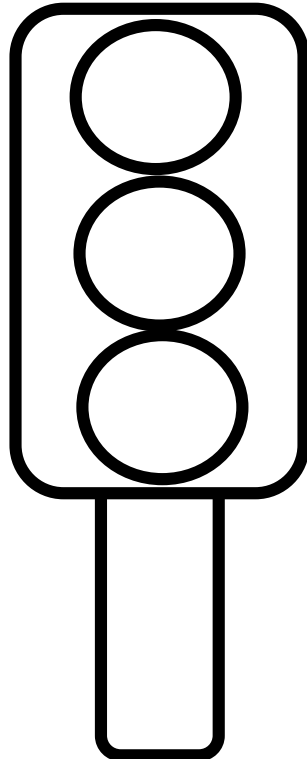
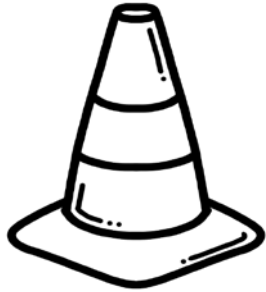
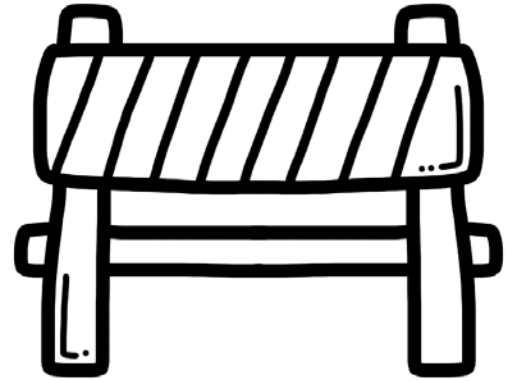
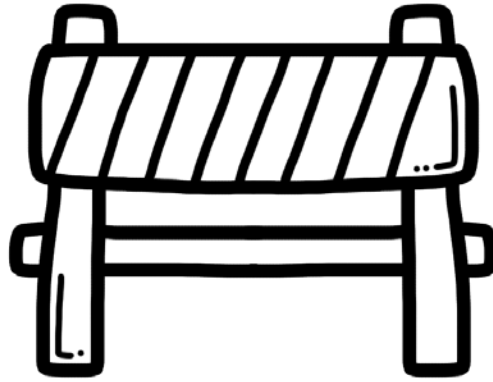
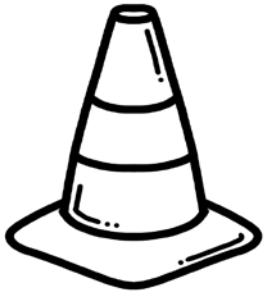

# Memory Game

Print pages 16-18 twice so that there are two of each helper. Use cardstock or laminate for durability. Cut out the cards and place them at a center to play "Memory". Students can pick and choose which helpers they want to play the game with (not all cards need to be used).



baker



construction  
worker



trash  
collector



judge



scientist



doctor

# Memory Game

Print pages 16-18 twice so that there are two of each helper. Use cardstock or laminate for durability. Cut out the cards and place them at a center to play "Memory". Students can pick and choose which helpers they want to play the game with (not all cards need to be used).



dentist



firefighter



mail carrier



nurse



police officer



farmer

# Memory Game

Print pages 16-18 twice so that there are two of each helper. Use cardstock or laminate for durability. Cut out the cards and place them at a center to play "Memory". Students can pick and choose which helpers they want to play the game with (not all cards need to be used).

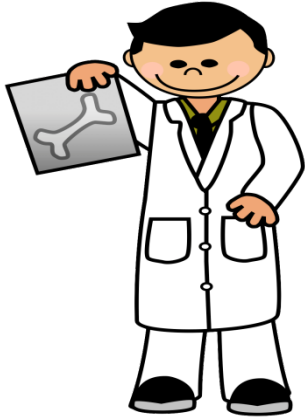

veterinarian

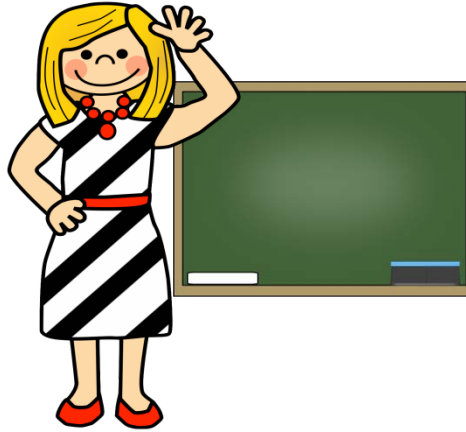

teacher



chef



pilot



news reporter



lawyer



# "HELPERS IN OUR TOWN" SONG

*(To the tune of "This Old Man")*

This baker she bakes bread...  
"I make treats" that's what she said.  
Now let's meet another helper in our town,  
Hello firefighter come on down!

This firefighter rides a truck...  
Puts out fires, and helps when you're stuck.  
Now let's meet another helper in our town,  
Hello doctor come on down!

This doctor, he is quick  
To help me feel better when I'm sick.  
Now let's meet another helper in our town,  
Hello teacher come on down!

This teacher teaches me  
123s and my ABCs.  
There are so many different helpers in our  
town,  
How many more can we name right now?

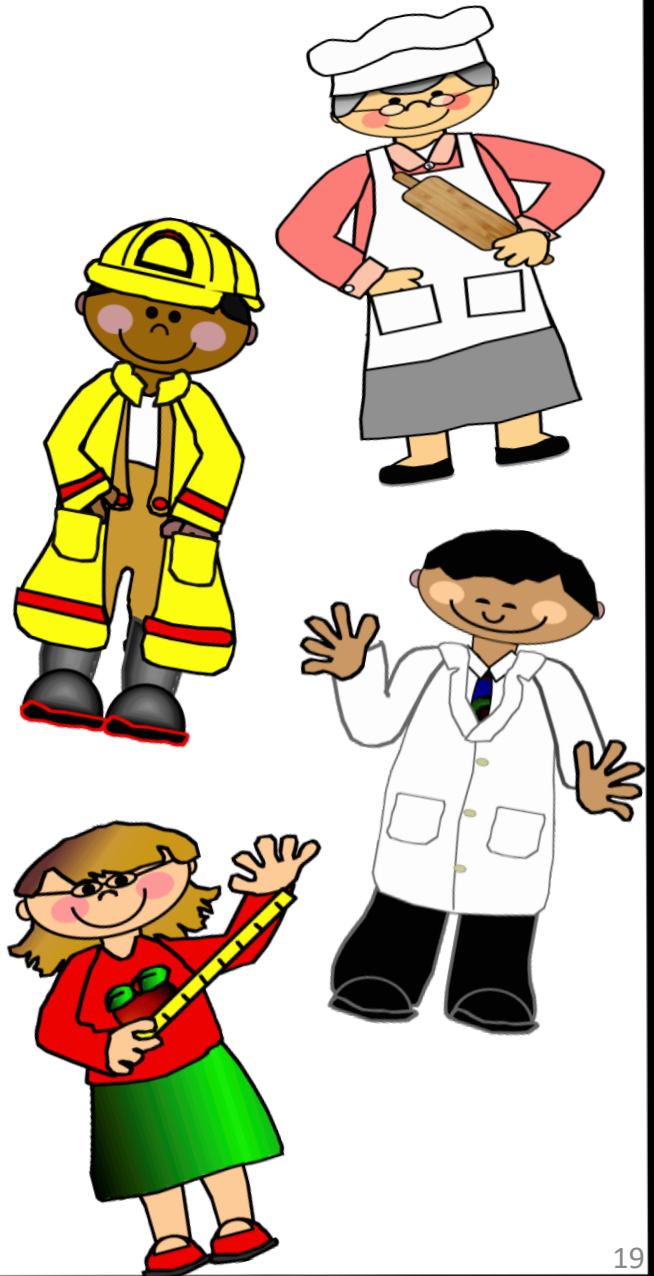



# GAME IDEAS!



## "Where's the Mail?"

Get an envelope and write on it to make it look like a letter.

Choose one child to be the mail carrier. They will need to figure out which child has the "mail".

Line the rest of the children up with their backs to the wall.

The mail carrier will face away from the children and close their eyes while you quietly hand off the mail to one of the other children.

All of the children must keep their hands behind their back.

The children say "mail carrier, mail carrier, where's the mail?"

The mail carrier turns around and gets three chances to pick which child is hiding the mail.

## "I'm Lost!"

Choose a child to play the police officer and have them turn around and face away from the rest of the group.

The teacher then will quietly point to one child from the group to be "lost".

Then the teacher calls out, "police officer, HELP, I lost my child!"

The police officer turns around and responds, "what does your child look like?"

The teacher gives the police officer 3 clues to help describe the lost child.

If the child still needs help, have the students add more clues.

The lost child then gets to play the police officer and so on.

# CODE 3 CLIP IT!

Directions: It's a code 3 emergency! The emergency response vehicles need to figure out the correct number in each tens frame.

Print and cut out each of the cards on pages 21-23. Use cardstock or laminate for extra durability. Place these in your math center along with clothes pins. Have students clip the correct number on each fire truck and police car.

Optional: Use the printable on page 24 for extra practice if desired.

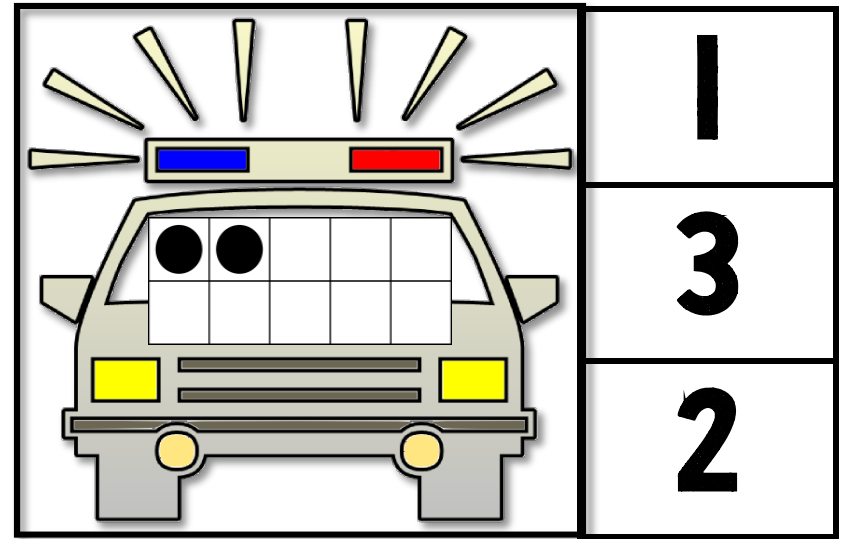
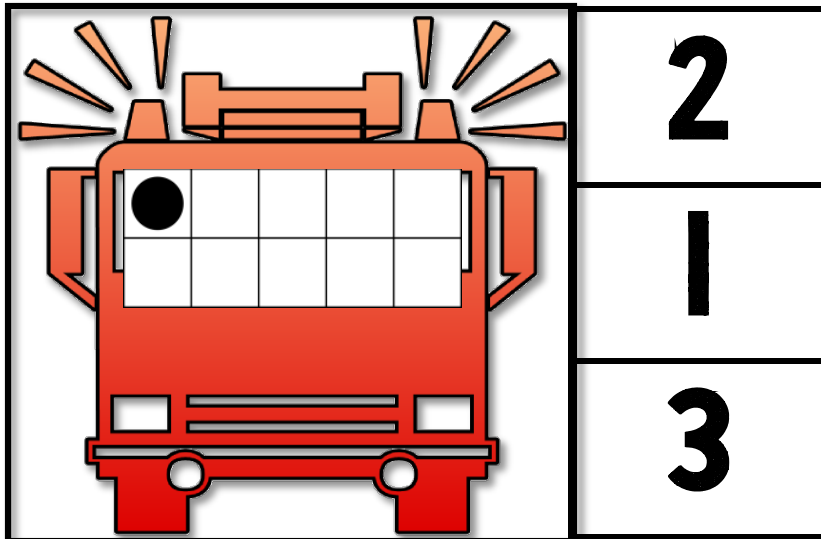
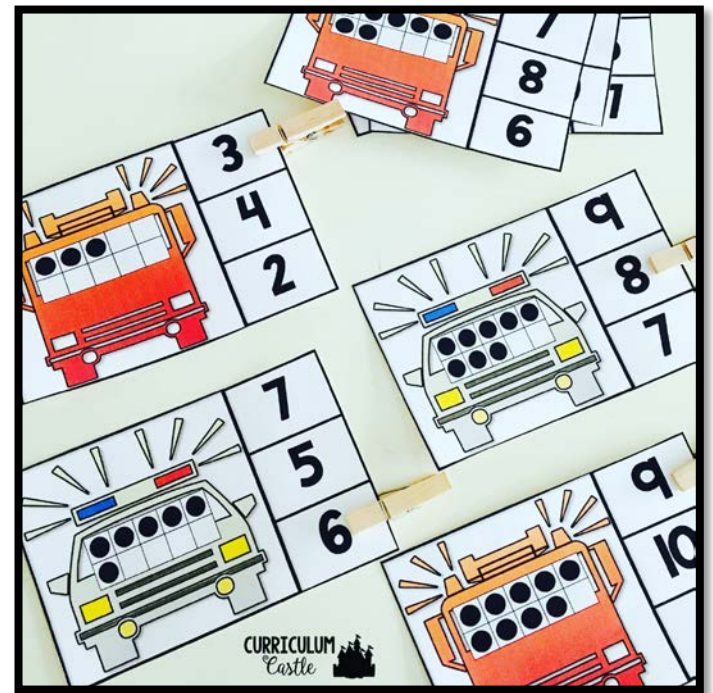

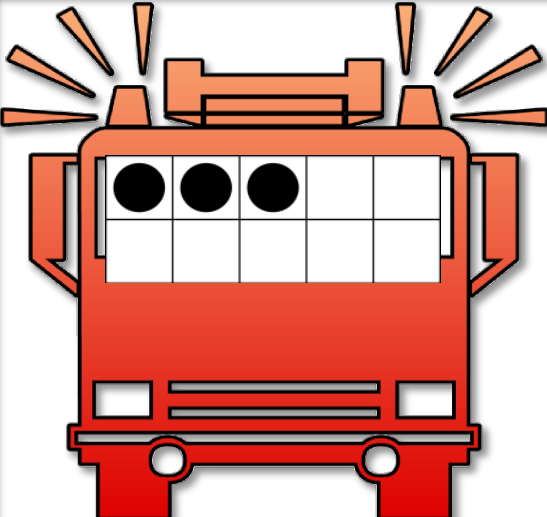
	3
	4
	2

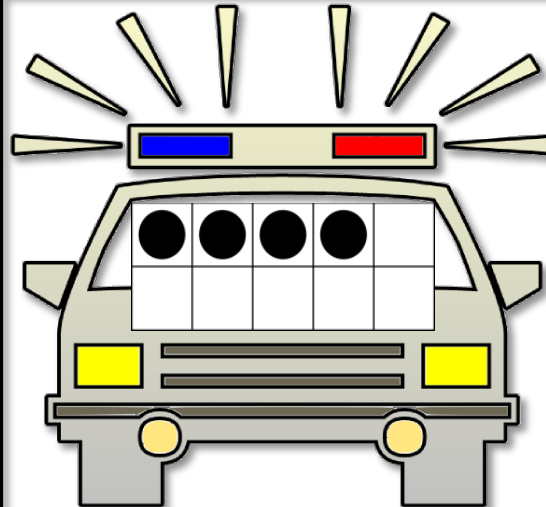
	5
	4
	3

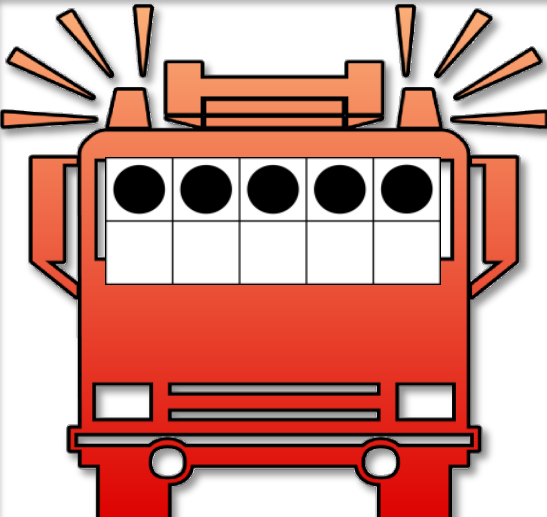
	5
	6
	7

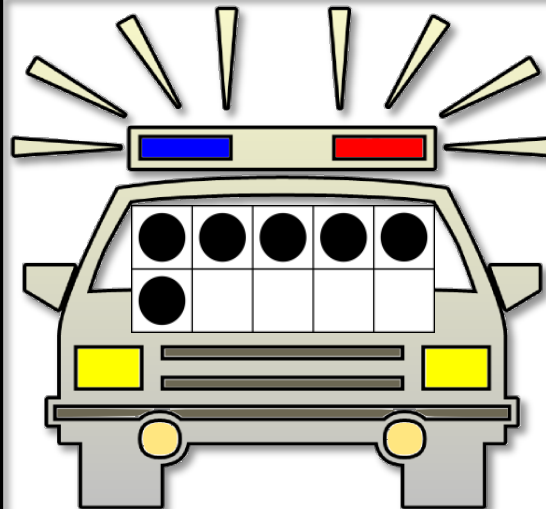
	7
	5
	6

	7
	8
	6

	9
	8
	7

	9
	10
	8

	8
	9
	10



Name: \_\_\_\_\_

# CODE 3 Number Emergency

Directions: Count the number of dots in each tens frame. Draw a line from each emergency vehicle to the correct number.

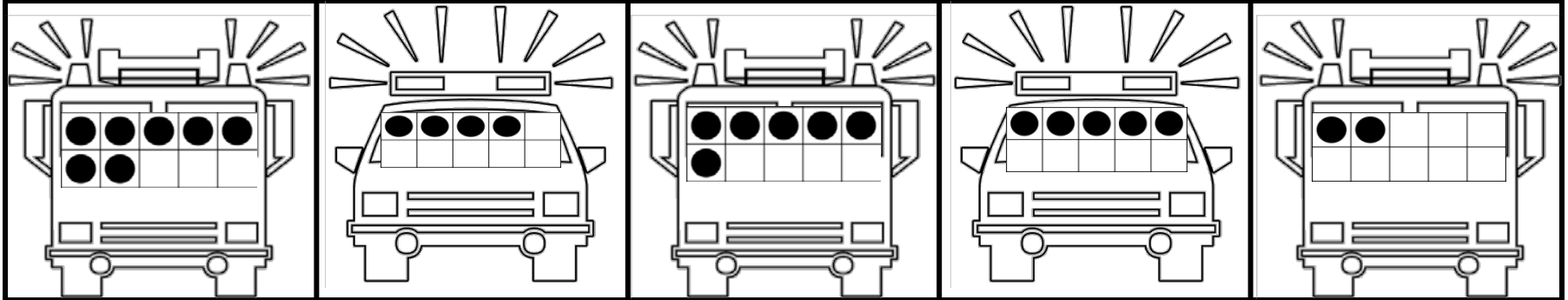

4

2

6

7

5

Name: \_\_\_\_\_

# The Community Helper in ME!

**When I grow up, I  
want to be...**





**This is me helping my  
community!**

Name: \_\_\_\_\_

# Community Helper

## Matching

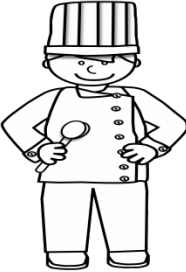
Directions: Cut and paste the object under the correct community helper.

 firefighter	 doctor	 construction worker	 chef	 scientist	 mail carrier

















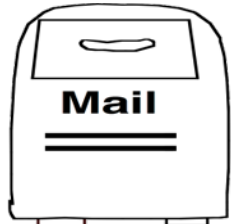



Name: \_\_\_\_\_

# What Comes







Directions: Cut and paste the object that finishes each pattern correctly.

# Next?

Copyright © 2013 Curriculum Castle

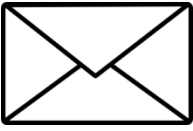

					
-------------------------------------------------------------------------------------	-------------------------------------------------------------------------------------	-------------------------------------------------------------------------------------	---------------------------------------------------------------------------------------	---------------------------------------------------------------------------------------	---------------------------------------------------------------------------------------

Name: \_\_\_\_\_

# How Much

# Trash?

Directions: Count the number of pieces of trash in each space below. Draw a line from each space to the correct trash collector.

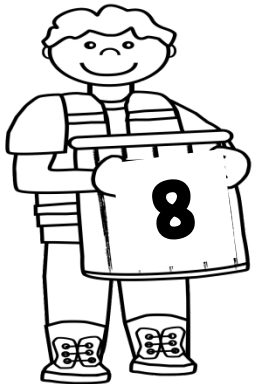
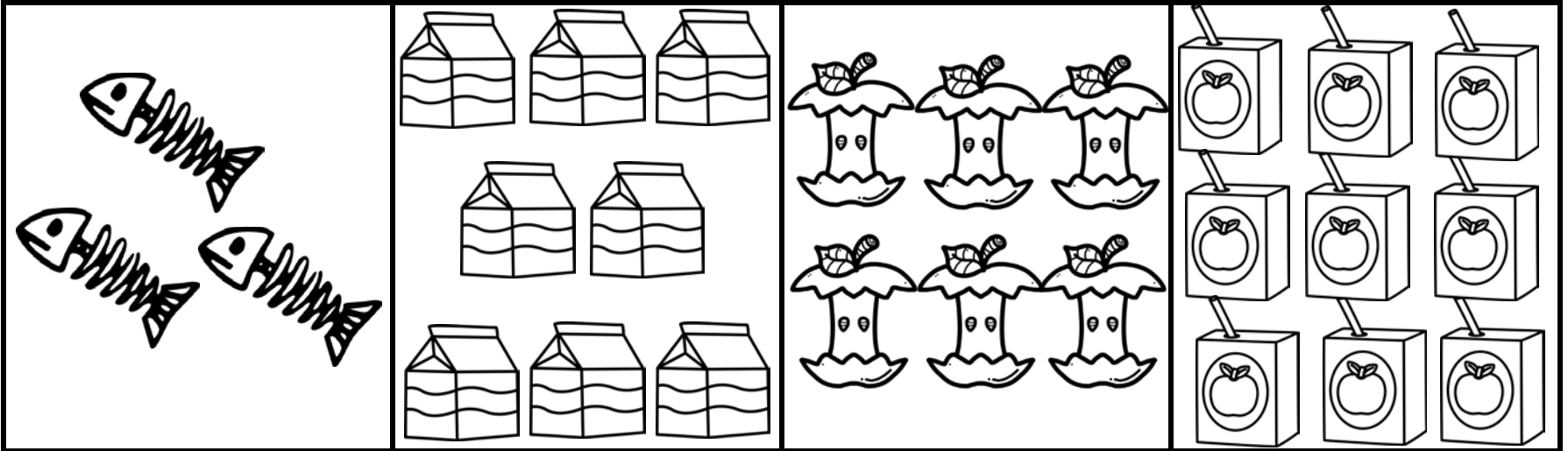



Name: \_\_\_\_\_

# Helping on the Farm

Directions: Help the farmer put only  
the farm animals in the barn.

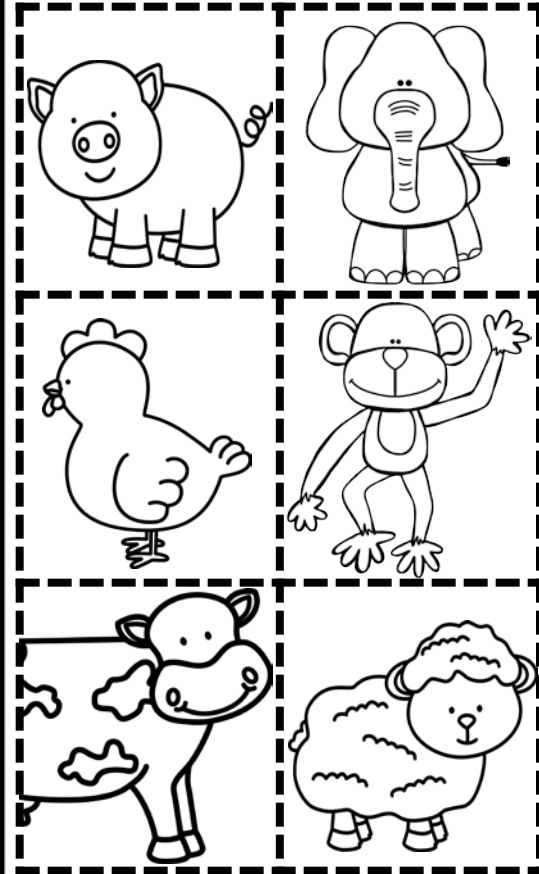

# Credits & Considerations

You MAY ALSO ENJOY:

CLIP ART AND FONTS BY:

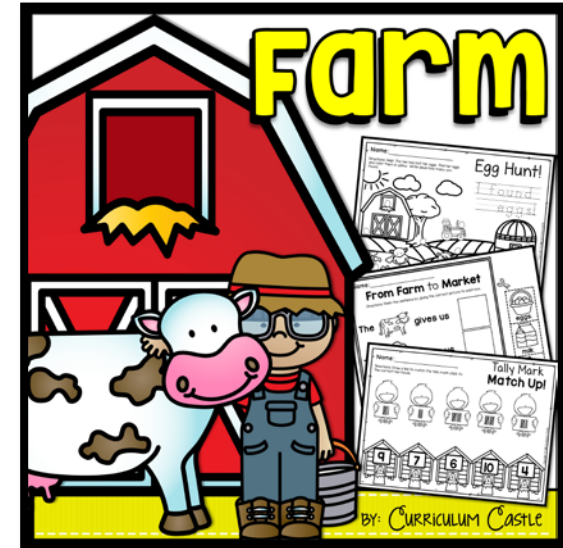

"This item is a paid digital download from our TpT store, Curriculum Castle, Inc.:

<http://www.teacherspayteachers.com/Store/Curriculum-Castle>  
by Yvette Florez and Jessica Ruiz. As such, it is for use in one classroom only.

This item is also bound by copyright laws and redistributing, editing, selling, or posting this item (or any part thereof) on the Internet are all strictly prohibited without first gaining permission from the author. Violations are subject to the penalties of the Digital Millennium Copyright Act. Please contact us if you wish to be granted special permissions!" [curriculumcastle@gmail.com](mailto:curriculumcastle@gmail.com)



Connect with us!



Thank you for your purchase! We appreciate your feedback. Please check out our store and don't forget to follow us for the latest FREEBIES and newly listed products.